

OEM/Designer Handbook:

Model K2 Long-Distance Microscope System



Infinity Photo-Optical Company • 2530 Frontier Ave. • Boulder, CO 80301 • Telephone 303/440-4544 • Fax 303/440-4144

Model K2 Long-Distance Microscope

Model K2 is the most versatile long-distance microscope available. The K2 is designed to operate from infinity down to 51mm, depending on how it is equipped with supplemental objectives. The K2 is a multi-purpose instrument, capable of use in visual, photographic or video modes. Depending on how it is equipped, accessories can be used to multiply, halve or zoom the K2's magnification or to adapt it to a range of video/photo cameras.

The K2 is composed of a Main Body which contains its patented AVS™ internal focusing system, activated by rotation of the focusing ring. A Clamp is provided (more can be obtained as accessories) to allow positioning and mounting capabilities. The K2 can be supplemented by a Focusing Ring Lock for special requirements. On its front is a dovetail flange which links to the various supplemental objectives. Each Objective (except CF-4) has a built-in holder with M49 threads, allowing standard photographic-type rotatable polarizers and color filters to be conveniently attached.

The Clamp can be exchanged with various Stereomicroscope Stand Adapters, should such mounting be required. Rear of the Clamp, various amplifiers (TR Tube, Zoom Module and/or DL Tube) can be attached. A 58mm spacer can be exchanged with a Mirror Diverter to convert single-port models for dual-port use.

Please refer to the accompanying drawings for configuration details. The configurations are specific for optical quality and should not be altered in any way from their approved positions. When video/photo adapters are used in direct macro mode, the M62 Eyepiece Holder must be removed. Do not attempt to use it as an extension tube, because the unoccupied smooth eyepiece bore will not only throw the K2's tubelength/corrections off, it will also produce intense glare and reflection, destroying image quality. The K2's unique design and internal focusing system make traditional "conventional wisdom" regarding extension tube use obsolete. If you think that some special requirement could be served by tube extension, please contact us for suggestions. Unauthorized use of the K2 can void its warranty.

Controls. Besides the focusing ring, the K2 has a built-in iris diaphragm for depth of field and light attenuation control. The iris can be observed directly by removing the eyepiece and looking down the tube. Since each object has its best overall iris setting due to inherent glare or contrast requirements, you may wish to employ the standard rule in microscopy (known as "Nelson's 3/4-aperture Rule") by closing-down the aperture 3/4 of the field observed. Alternately, after some practice, the effect of the aperture on the object's image can be observed by a sudden "jump" in image quality (the so-called "oomph" position). Although it can be used full-open for highest theoretical resolving power, the K2--like all other compound microscopes--benefits from "Nelson's Rule."

Amplifiers. The K2's magnification *presumes* one amplifier in-system. Amplifiers are lenses that supplement the K2's magnification by 2x factors. Please refer to the drawings for the proper amplifier

position. The DL Tube can be ganged with another of its own kind and fits between video camera and C-mount. Two ganged DL Tubes provide 4x amplification, or 2x K2 rated power

When an amplifier is removed (using a 2-56 Allen wrench to first loosen the setscrews at the bottom of most tubes), the K2's power is *half that listed on the chart/graphs*. If the K2 is used in video mode, the Tele-tube can be used to set the K2's rated power to 0.25x its normal range.

Video/Photo. Refer to the drawings for appropriate macro (direct to sensor/film) and photomicro (eyepiece/Unipar adapter in-system). The Unipar multiplies the power of any eyepiece used with it by a 0.3x factor (10x eyepiece becomes a 3x photo projection). A special Unipar-V with 0.2x factor can be used for video. Combined with a 5x eyepiece, the total magnification on-sensor is 1x factor. (This system makes it possible to mount a reticle in an eyepiece, imaging the reticle onto the sensor simultaneously with the object's image, and still retain 1x factor).

Illumination. The K2 functions best when the objective is as evenly and as brilliantly illuminated as possible. Intense lamps or fiber optic illuminators should be used. An adapter is available to mount 66mm fiber optic ring lights to the filter holders of all objectives except the CF-4. Flash (strobe) units provide excellent color characteristics, and most modern SLR's now accurately meter flash off the film-plane.

Stands. The K2 can be mounted on any heavy-duty video-type floor-standing tripod or jig which can secure it either by standard 1/4-20 screws or M4 screws (mounted outboard on the K2's mounting clamp). In addition, INFINITY manufactures adapters for major-brands of "boom-type" stereomicroscope stands [e.g., Bausch & Lomb (Leica), Olympus, Nikon, Unitron, etc.].

Further Possibilities. The K2 is part of a comprehensive line of instruments made by INFINITY. As such, it is possible to mate many accessories for special purposes. Motor drives are available for focus, zoom—or both—controlled simply, by computer interface or by an autofocus module. Please do not hesitate to contact us with potential uses/configurations, since we have extensive experience in special-model configurations.

Accessory Weight. The K2 should not be abused with extra-heavy, unsupported weights. The greatest weight that should ever be placed directly on a port is 1-1.5 kilos. Beyond that, heavy cameras should be supported independently. We will be pleased to advise.

Care and Cleaning. The K2 should be treated as the fine optical instrument that it is. Care should be taken to keep dust and dirt off external lens surfaces. The unit can be cleaned (metal parts only) by a cloth moistened with alcohol. The external optical surfaces should be cleaned only when necessary, and then, only by a soft cotton swab moistened by an approved optical glass cleaner. If you have further questions, please contact Infinity Photo-Optical Company or your authorized dealer.

K2 OPTICAL DATA

K2	STD		CF-1		CF-1/B		CF-2		CF-3		CF-4	
	Near	Far	Near	Far	Near	Far	Near	Far	Near	Far	Near	Far
WD mm	440	1350	272	660	225	457	140	214	90	125	51	63
MAG	1.5	0.45	2.3	0.9	2.8	1.5	4.0	2.5	5.8	4.0	10.7	8.0
FOV mm	4.4	14.1	2.8	7.0	2.3	4.2	1.6	2.6	1.1	1.6	0.6	0.8

*FOV based on 1/2" video format (6.4mm horizontally). See Video Format Page.

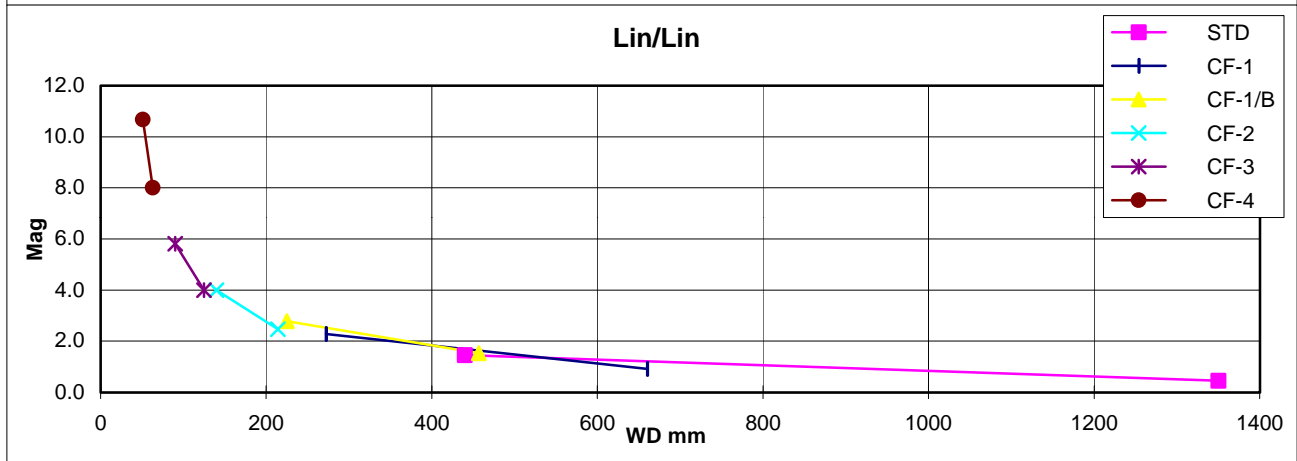
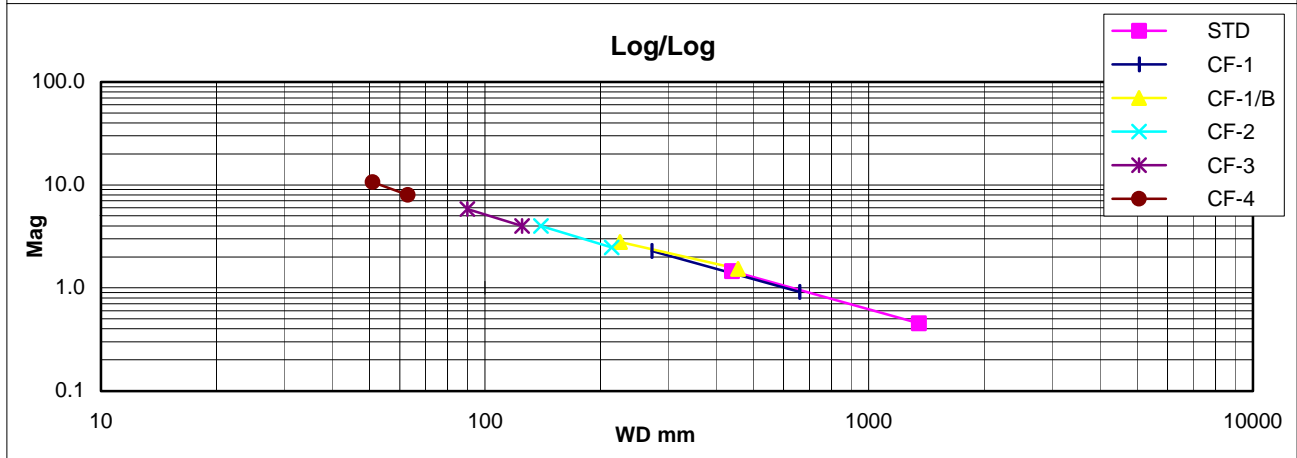
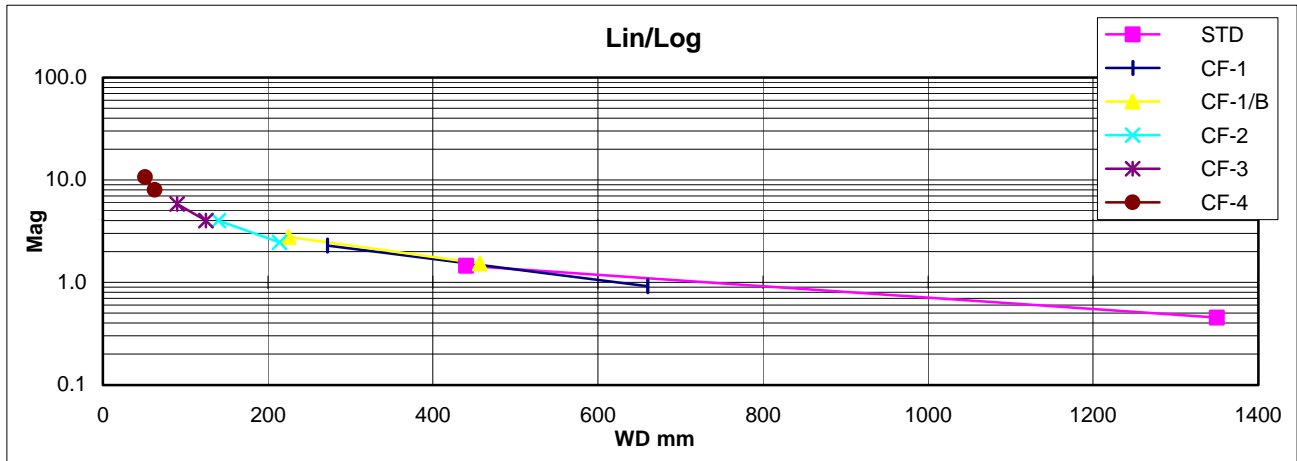

Video Formats

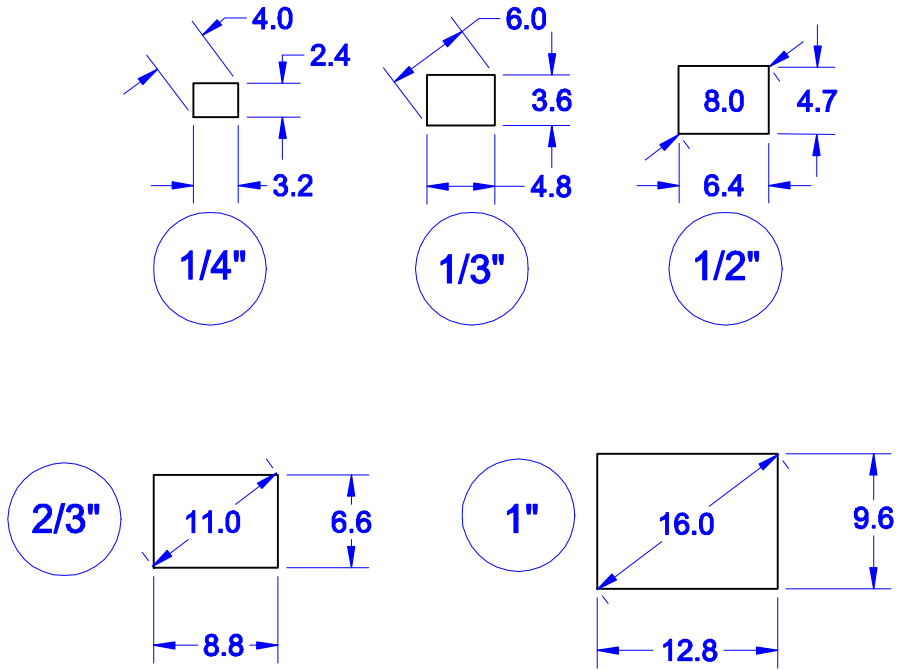

Eyepiece Formats

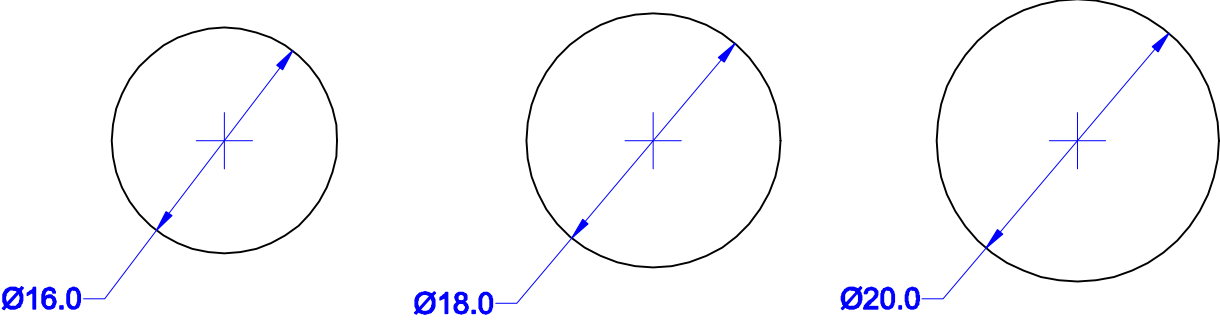

All dimensions in mm.

K2 Main Body Options

K2 Main Body w/Clamp

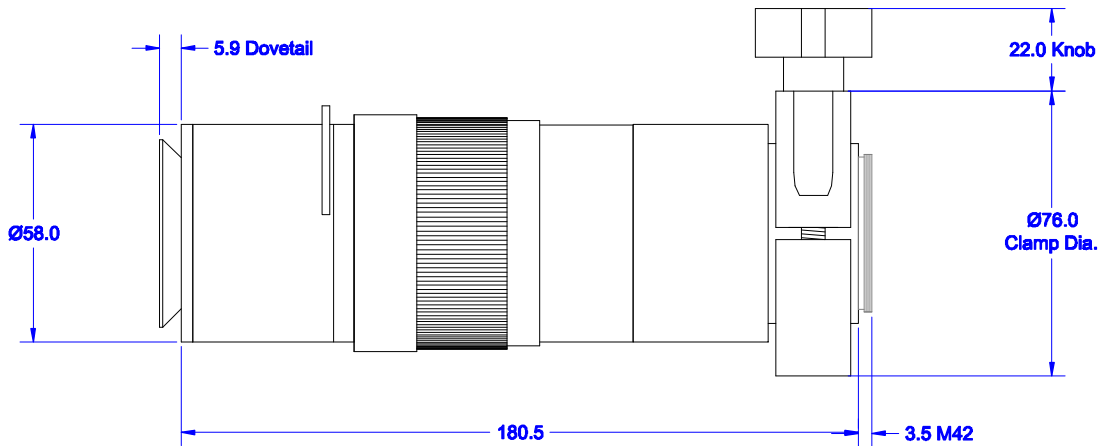

w/TR Tube

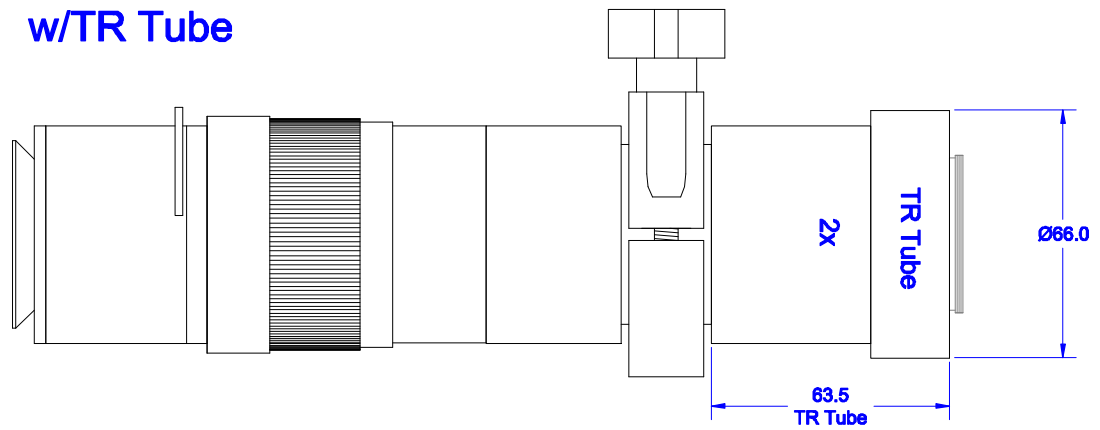

w/Zoom

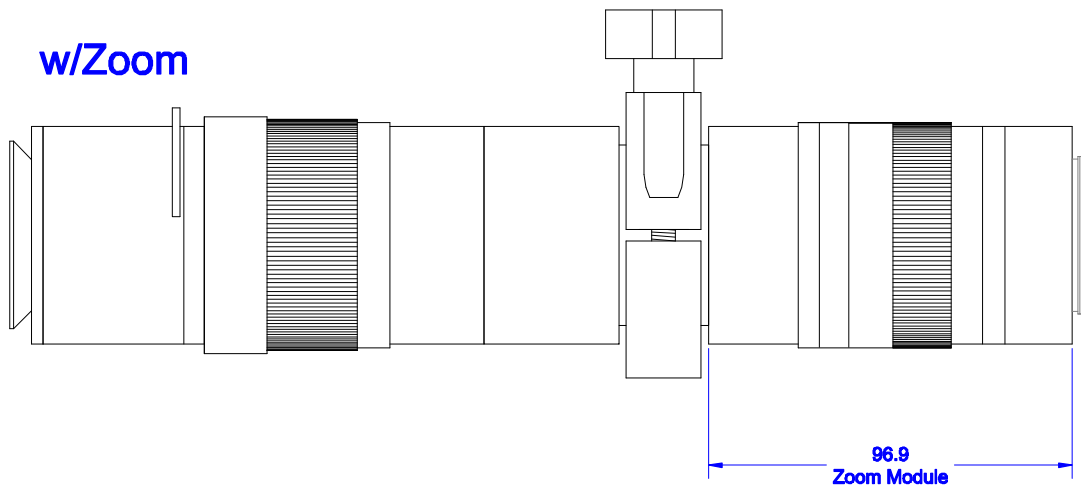

K2 Video Mode

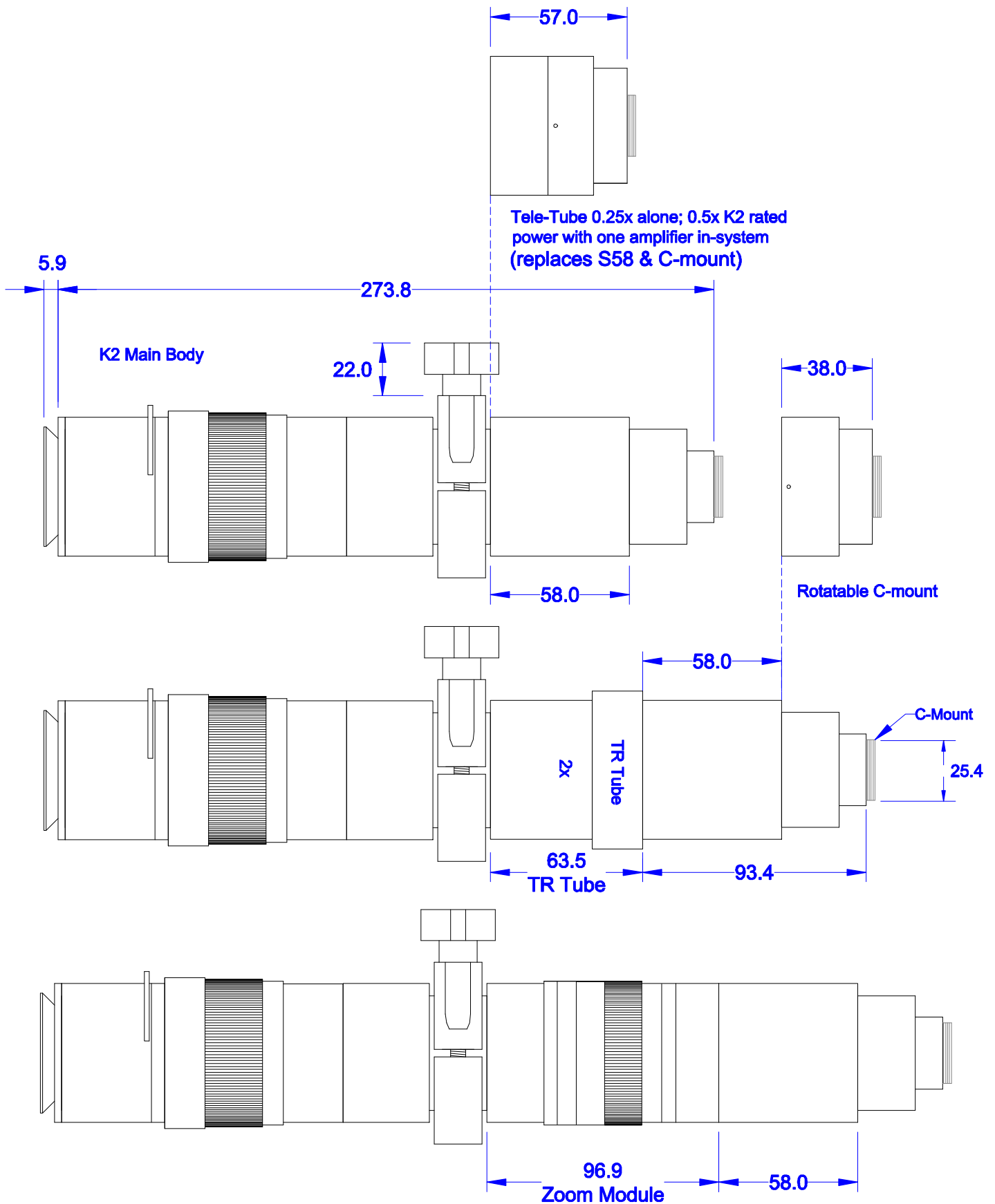

K2 Direct Mode for Large Format Video & Photo

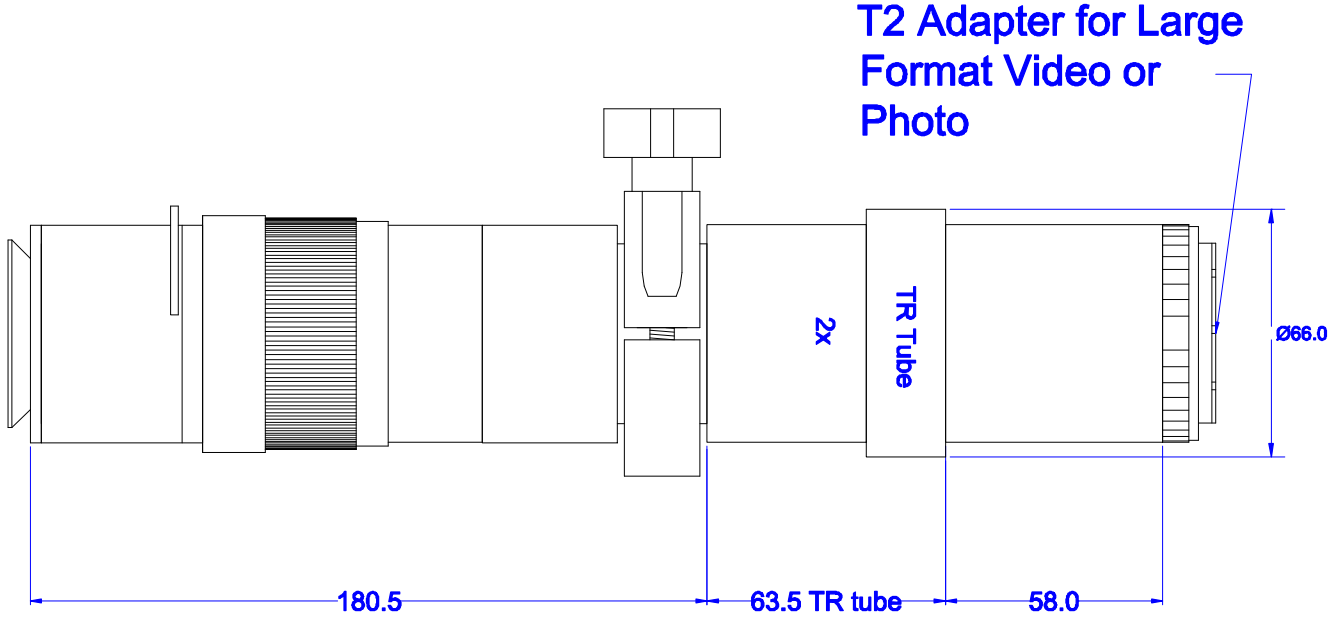

NOTE: For Dual Port Mirror Diverter replace 58mm section.

Visual

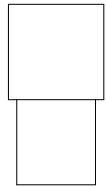

Eyepiece

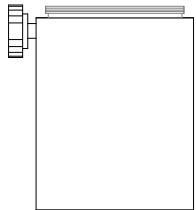

M62 monocular

Photo or Large-Format Video

SLR Body (or LF-Video) Camera

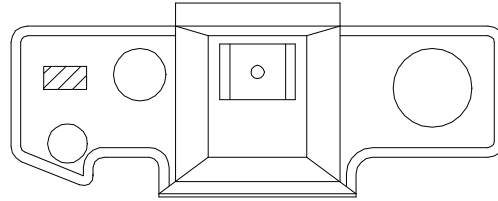

T2 mount



C-mount

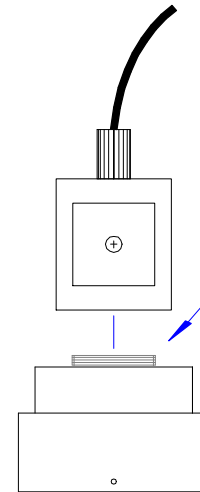

Video

2x DL Doubler

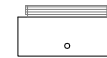

Tele-Tube

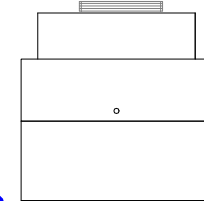

(w/ Tele-Tube 0.5x when used to replace 58mm tube and C-mount)

Attach to instrument

ALL DIM ARE mm.
FOR REFERENCE
ONLY. SUBJECT TO
CHANGE.

INFINITY Photo-Optical Company
2530 Frontier Ave., Boulder, CO 80301
303/440-4544 Fax 303/440-4144

Direct-Imaging Options

Rel 8/28/97

SIZE
B

FSCM NO.

DWG NO.

REV

Rev 11/20/97

SCALE NONE

SHEET 1 OF 1

K2 Visual & Photomicro Mode

w/ M62 Eyepiece Holder tube

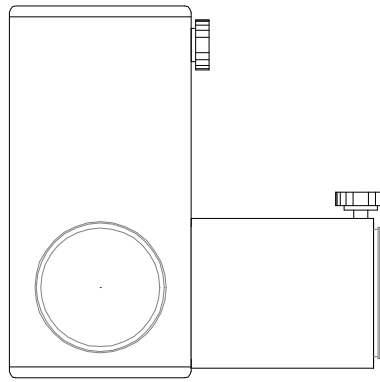

Mirror Diverter

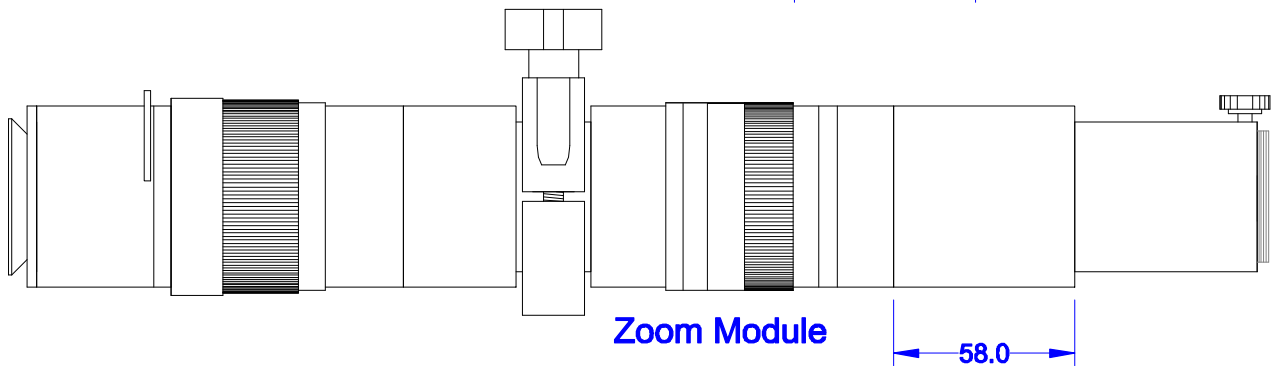
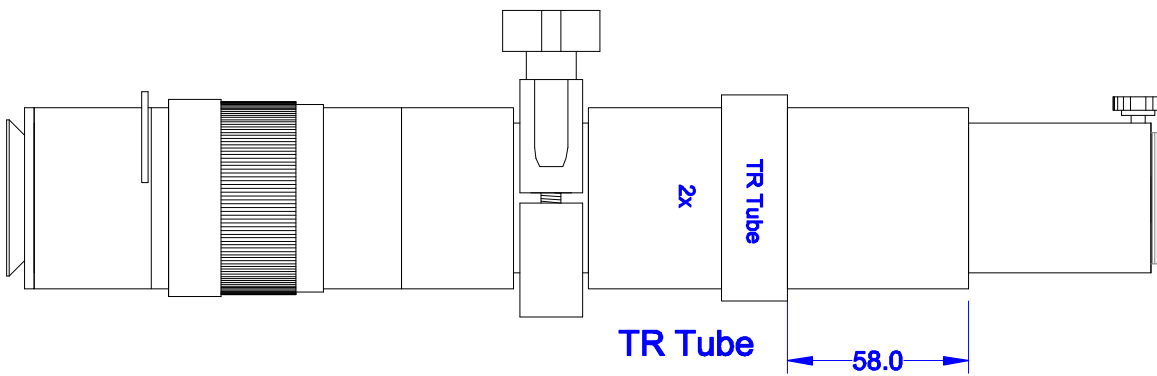
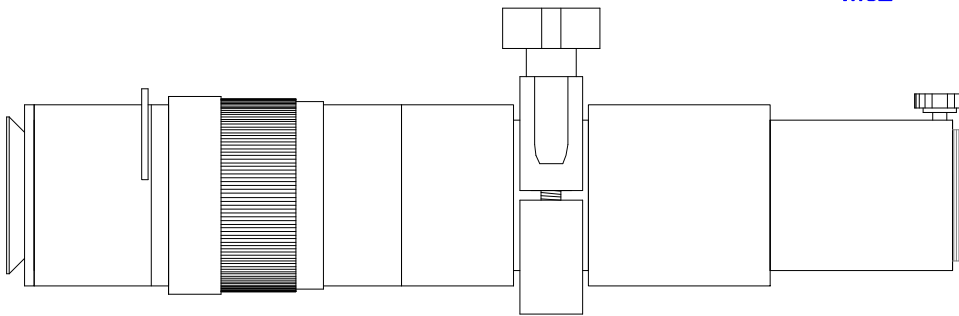
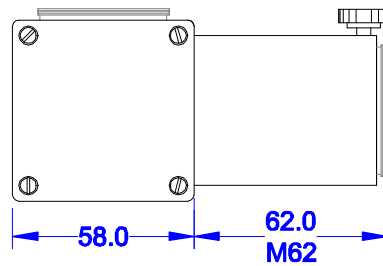

NOTE: 58mm tube can be exchanged with Mirror Diverter

Photo/Large-Format Video

SLR Body (or LF-Video) Camera

Video

2x DL Doubler

2x DL Doubler

C-mount

T2 mount

Unipar-Vid 0.2x video adapter

Unipar 0.3x video/photo adapter

or

T30 spacer

Eyepiece

M62 monocular

to Instrument

ALL DIM ARE mm.
FOR REFERENCE
ONLY. SUBJECT TO
CHANGE.

INFINITY Photo-Optical Company
2530 Frontier Ave., Boulder, CO 80301
303/440-4544 Fax 303/440-4144

Photo/Video Micrographic Options

SIZE	FSCM NO.	DWG NO.	REV
B			
SCALE	NONE		SHEET 1 OF 1

8/28/97

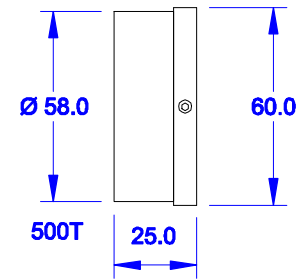
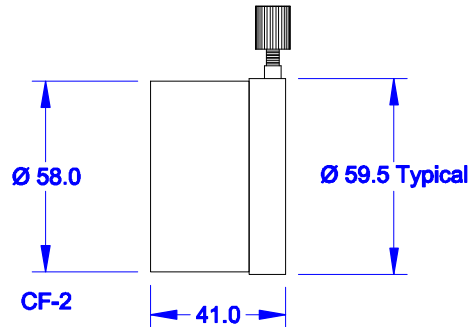
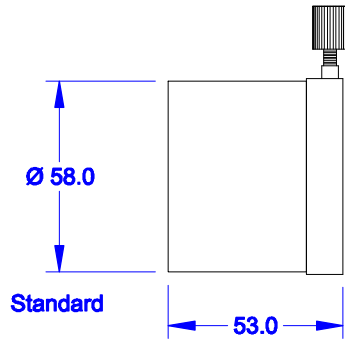

Note: The 500T objective transforms the K2 into an industrial telescope capable of focusing from 700mm to infinity.

To K2 Dovetail (see K2 drawings)

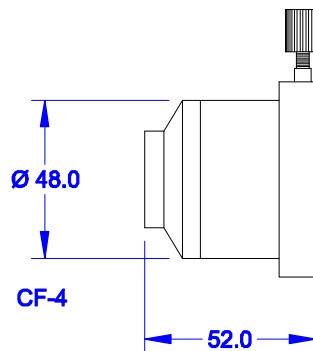
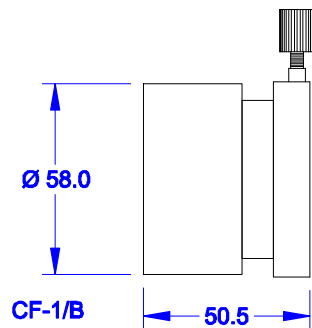
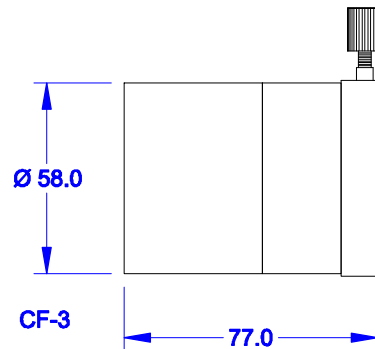
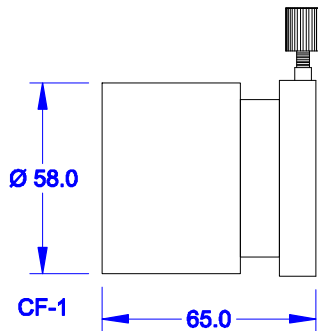

Notes: See attached tables and graphs for specifications.

ALL DIM ARE mm. FOR REFERENCE ONLY. SUBJECT TO CHANGE.	 INFINITY Photo-Optical Company 2530 Frontier Ave., Boulder, CO 80301 303/440-4544 Fax 303/440-4144			
	K2 Objectives			
8/5/97	SIZE B	FSCM NO.	DWG NO.	REV
SCALE	NONE	K2 Objectives	SHEET	1 OF 1

K2 Shown with Mirror Diverter w/Visual & Video Options

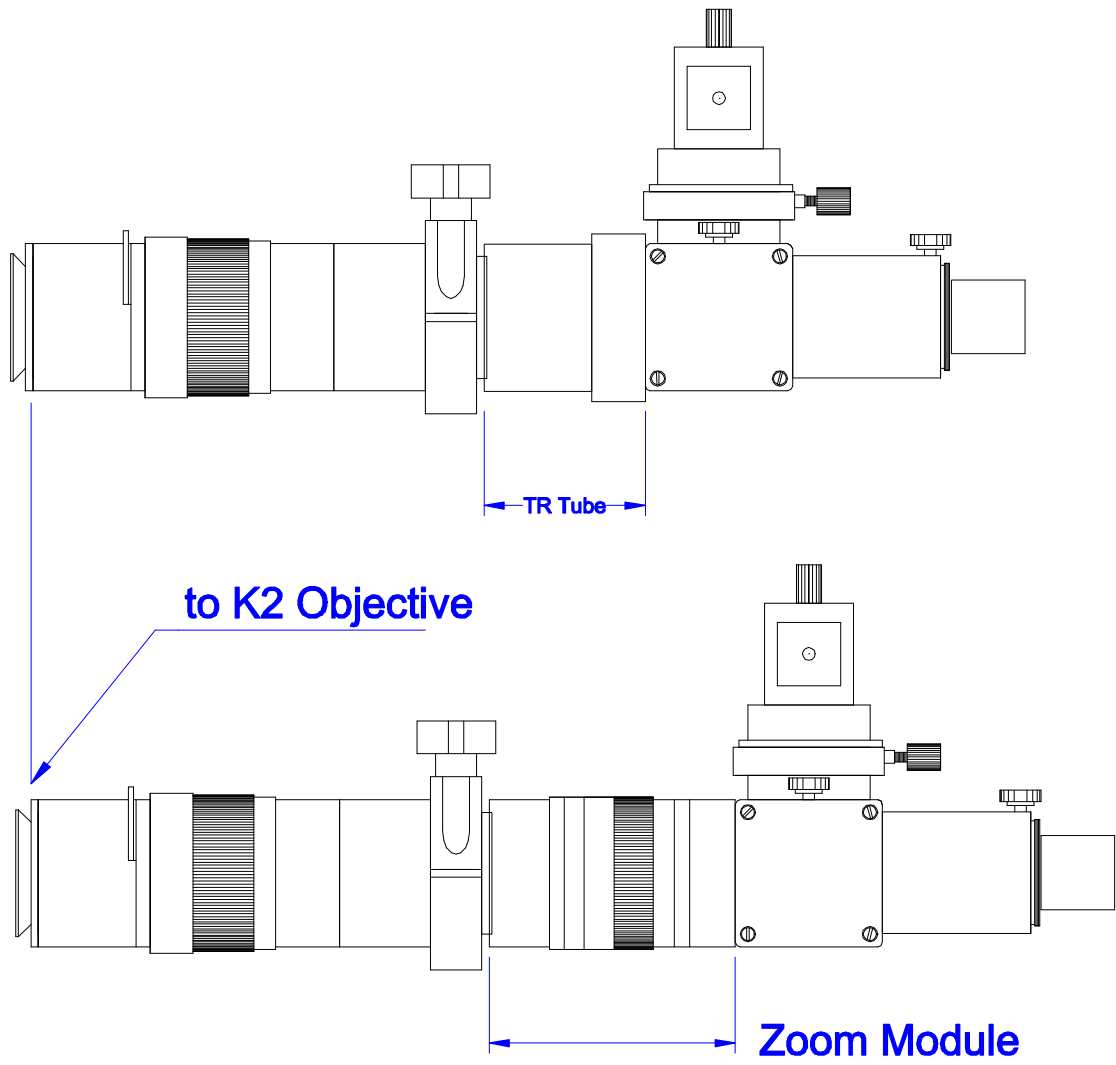
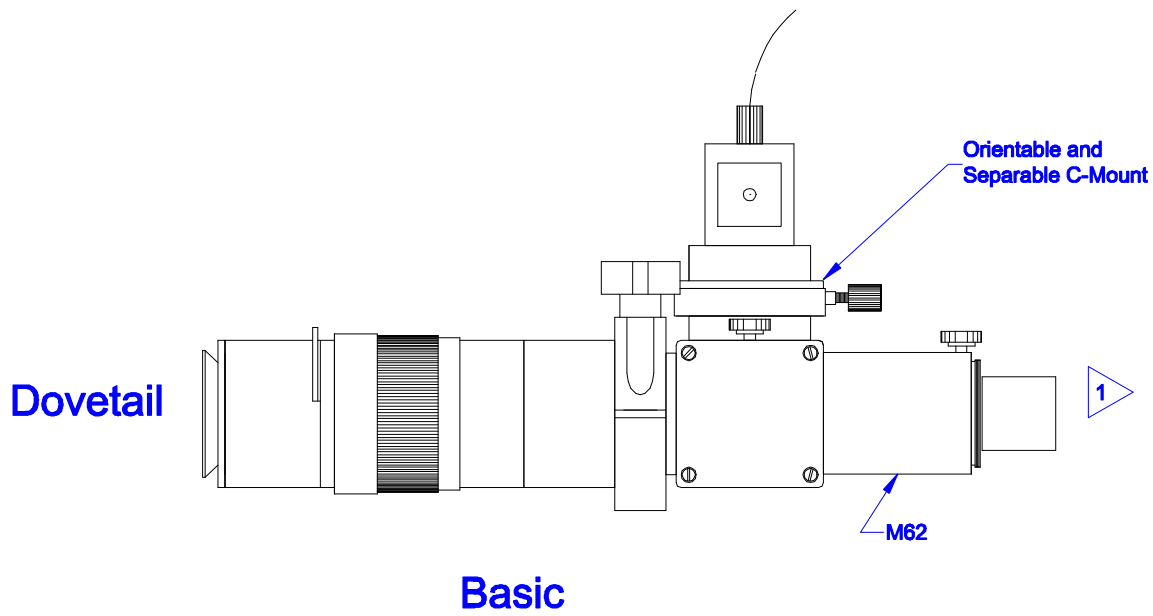

1 Use Orientable/Separable #770509 C-Mount or Rotatable #770511 C-Mount at this position in place of M62 for right angle orientation.

K2 Mounting Options

Infinity's Stereo Stand Adapters are integral tube replacements--not fallible slip-rings (as used by other manufacturers). Stand mounts can be substituted as follows:

K2 Main Body w/Clamp

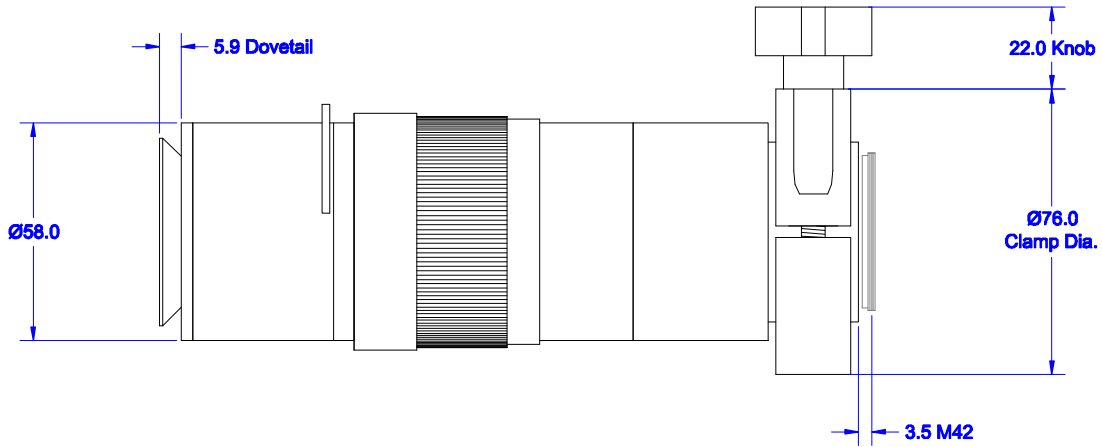

K2 Main Body w/Stereo Stand Adapter (Olympus)

(Adapters are also available for other major brands: B&L/ Leica, Nikon, Unitron, Will-Wetzlar/Hund).

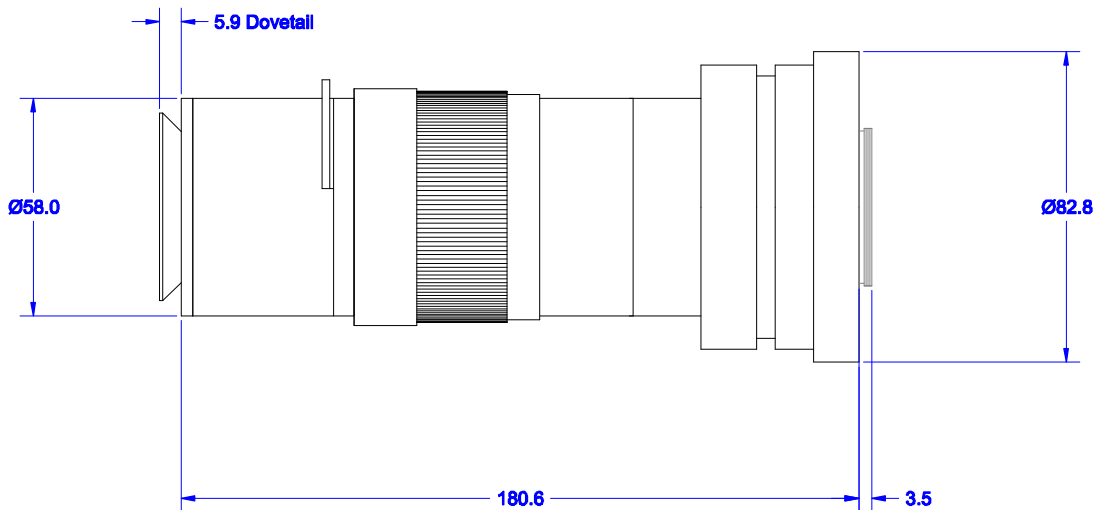

Note: Use 2-56 Allen head wrench to loosen setscrews on Clamp/T24 and replace with Stereo Stand Adapter.

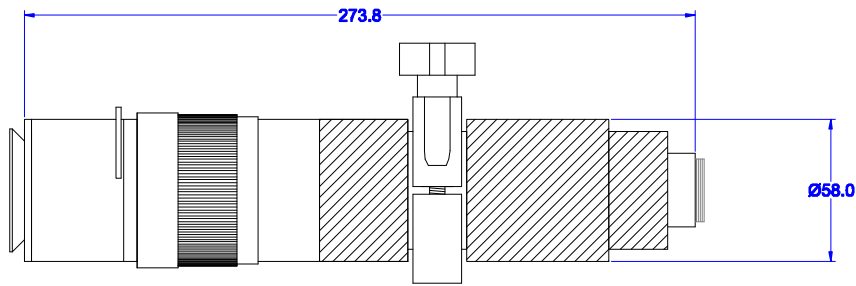

Main Body

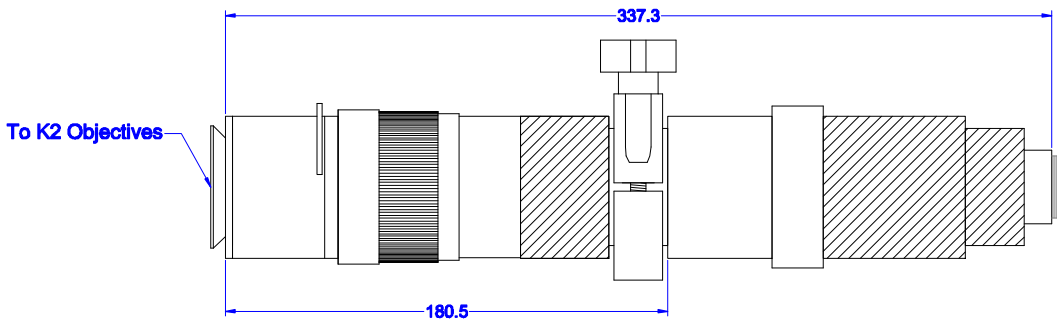

With TR Tube (Doubler)

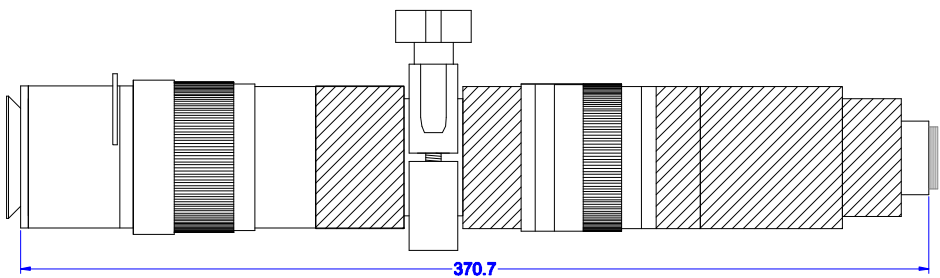

With Zoom Module

Hatching represents clamping zone with T-tube substitution.

ALL DIM ARE mm
[inches] AND ARE FOR
REFERENCE ONLY
AND ARE SUBJECT TO
CHANGE.

INFINITY Photo-Optical Company
2530 Frontier Ave., Boulder, CO 80301
303/440-4544 Fax 303/440-4144

K2 Overall Dimensions and Clamping Zones

Date:	SIZE B	FSCM NO.	DWG NO.	REV
Modified: 7/24/97	SCALE	NONE	SHEET	1 OF

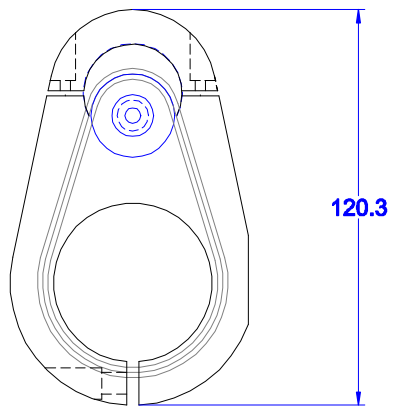
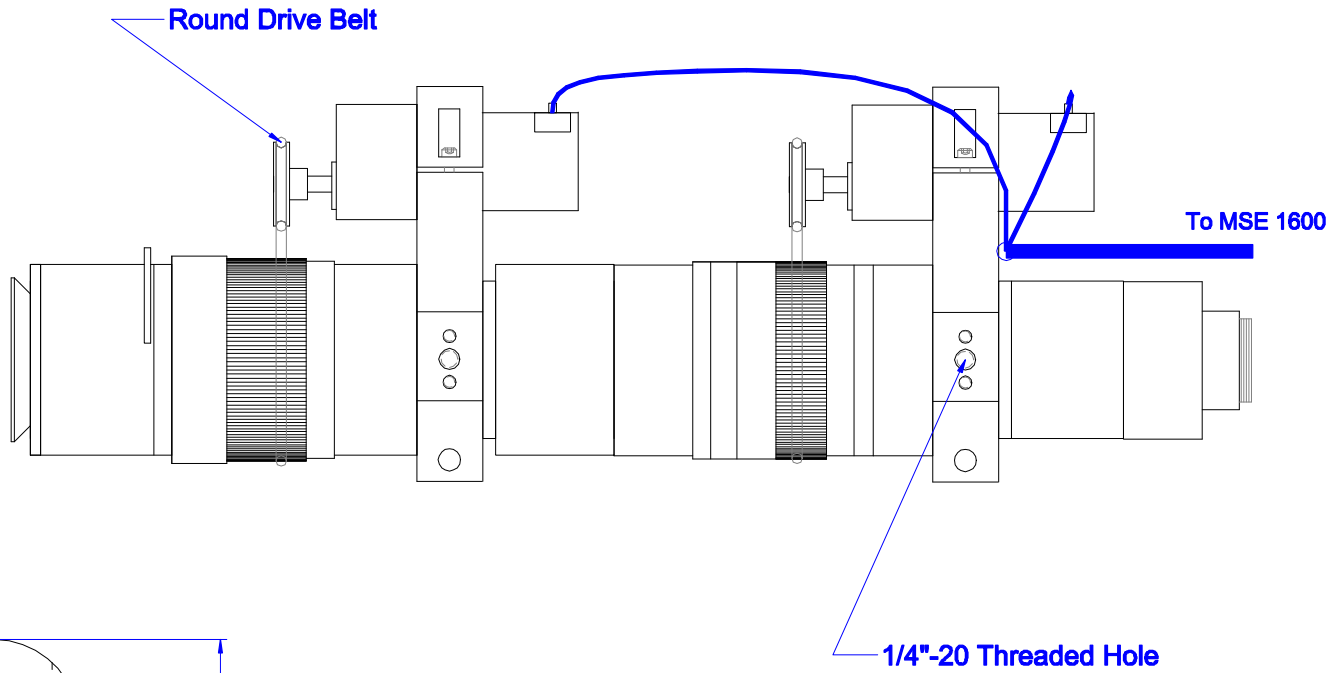

MSE 1000 End View

ALL DIM ARE mm
[inches] AND ARE FOR
REFERENCE ONLY
AND ARE SUBJECT TO
CHANGE.

INFINITY Photo-Optical Company
2530 Frontier Ave., Boulder, CO 80301
303/440-4544 Fax 303/440-4144

K2 with Motor Drives

Date: 10/09/97	SIZE B	FSCM NO.	DWG NO.	REV
Modified:	SCALE NONE	SHEET 1 OF		

SIDE

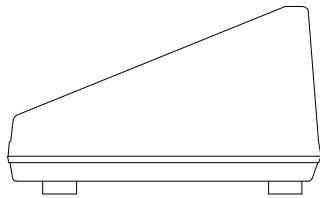

FRONT

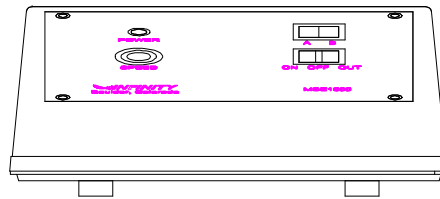

REAR

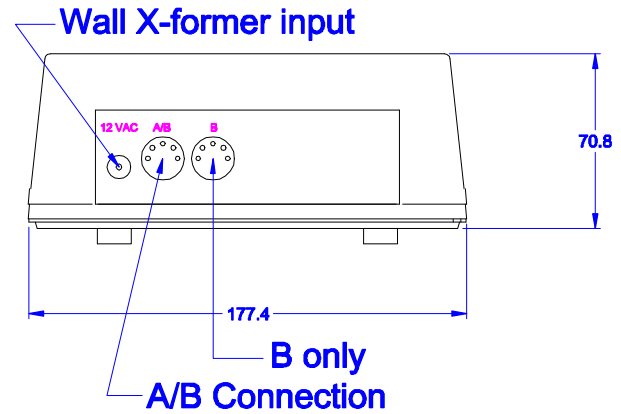

Power LED

Select A or B Motor

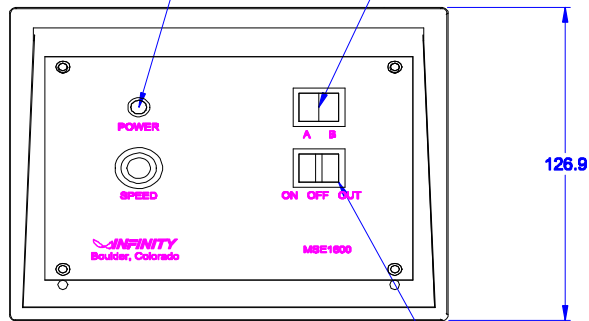

TOP

Forward/Reverse Paddle Momentary Center Off Switch

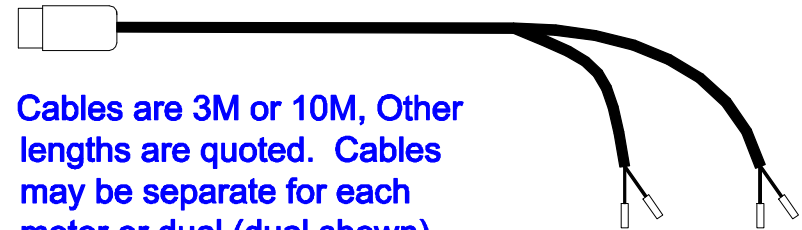

Cables are 3M or 10M, Other lengths are quoted. Cables may be separate for each motor or dual (dual shown).

ALL DIM ARE mm [inches] AND ARE FOR REFERENCE ONLY AND ARE SUBJECT TO CHANGE.

Date: 10/14/97

Modified:

INFINITY Photo-Optical Company
2530 Frontier Ave., Boulder, CO 80301
303/440-4544 Fax 303/440-4144

MSE1600 Motor Controller

SIZE B	FSCM NO.	DWG NO.	REV
SCALE NONE	SHEET 1 OF		

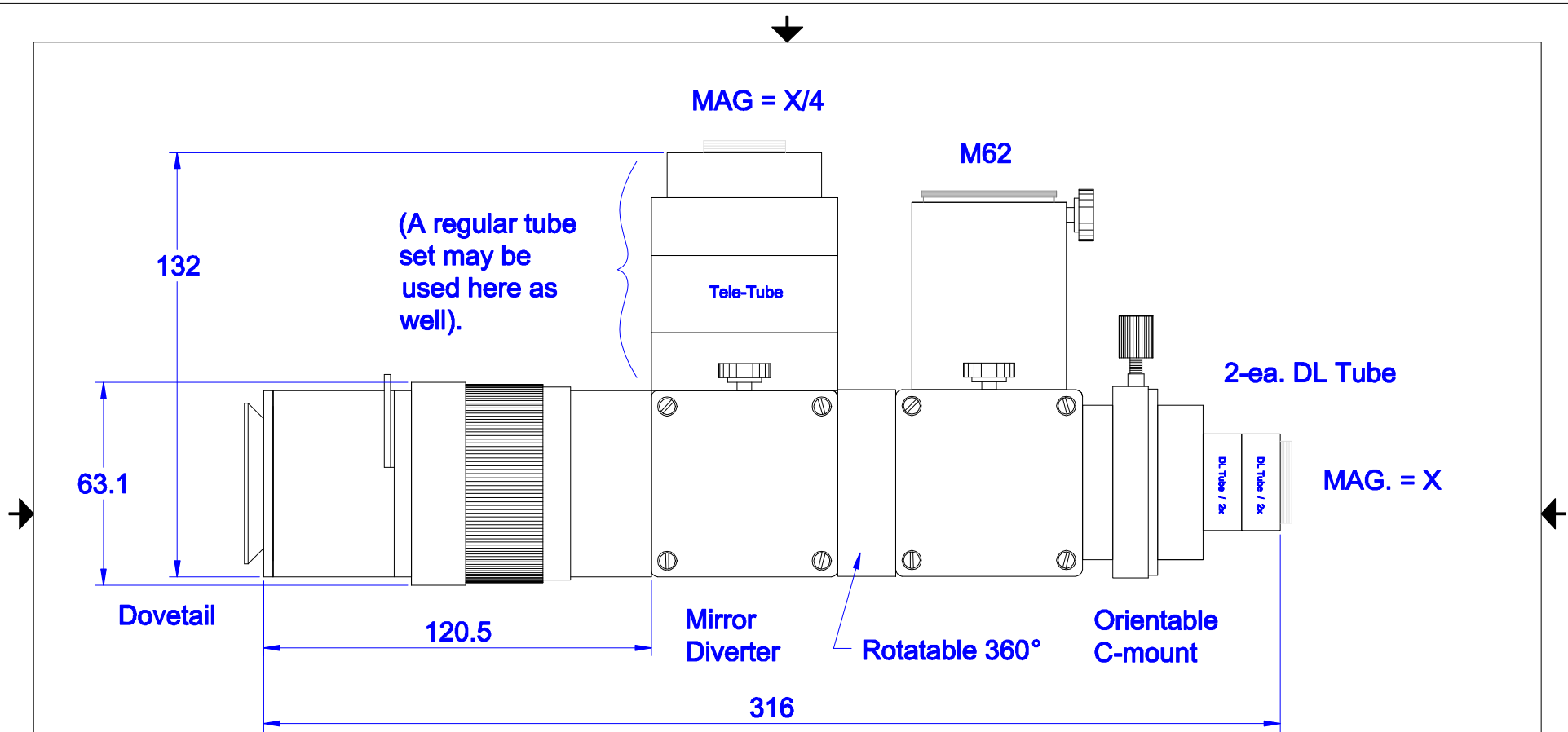

Note: 18mm has been added to system length.

ALL DIM ARE mm [inches] AND ARE FOR REFERENCE ONLY AND ARE SUBJECT TO CHANGE.		 INFINITY Photo-Optical Company 2530 Frontier Ave., Boulder, CO 80301 303/440-4544 Fax 303/440-4144	
Date: 6/10/97		K2 w/Double Mirror Diverter	
SIZE B	FSCM NO.	DWG NO.	REV
Modified: date 7/24/97	SCALE NONE	SHEET 1 OF	